



USEA CROSS-COUNTRY COURSE DESIGN GUIDELINES

PREAMBLE

These Guidelines are a reference point for USEA officials. They are not a rule book or a stand alone document, but rather a supplementary guide alongside the USEA Education Program.

The purpose of the Guidelines is to help with the designing and evaluation of cross-country courses and to help USEA officials achieve the same standard and level of safety for horses and riders at all affiliated events.

Any fence built where the design falls outside of this guide should be to a standard for its level of competition and should be the subject of a discussion between the course designer (CD) and technical delegate (TD) who should be in agreement before the start of the competition that the question is appropriate.

DEFINITION OF JUMPING EFFORT

An effort is any fence/obstacle that requires a horse to make a jumping effort. At Beginner Novice and Novice, a walk through water should be flagged and counted as a jumping effort. At Training through Advanced, a walk through water may not be flagged and not counted as an effort.

OBSTACLES WITH ALTERNATIVES

An obstacle with one or more alternatives should be counted as one effort as long as the CD and TD agree that the average horse will take the direct route.

Dimensions of alternatives should be in accordance with the level and where possible the 'Black Flag' rule should be used to create smooth lines and 'flow.'

Alternatives with extra efforts are better than requiring horses to do a circle as part of an alternative route.

HEIGHTS AND OBSTACLES

With the exception of the first fence and where detailed in these guidelines, all fences at every level should be built to maximum dimensions.

Fences should always be measured on the intended jumping line. CDs and TDs should also take this into account when measuring top and base spreads.

The rule does not mean that all parts of a fence between the flags has to be within height limits, but rather all parts that the CD and TD expect the average horse and rider to jump.

DIMENSIONS OF OBSTACLES

Please refer to Appendix 2, Specification for Horse Trials in the *USEF Rules For Eventing*.

ILLUSTRATION OF MEASUREMENTS From the *FEI Eventing Cross-Country Guide for Officials*

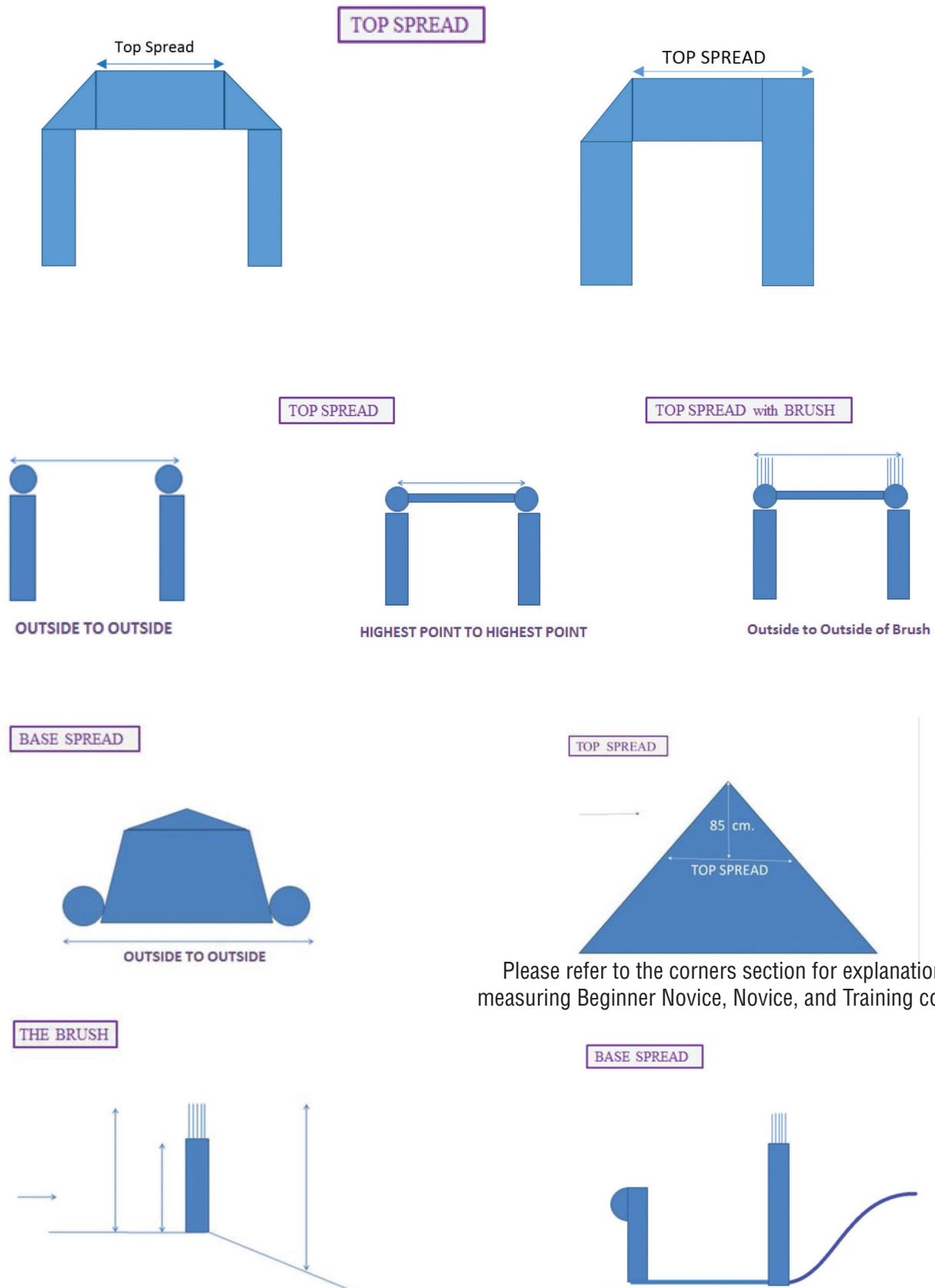

Please refer to the corners section for explanation of measuring Beginner Novice, Novice, and Training corners.

GENERAL GUIDELINES

- No fence can ever be justified by the use of an alternative(s) or frangible technology.
- No fence can be jumped in two directions unless it is a 'Black Flag' and then only if it is not frangible.
- All frangible fences must be jumped in the direction of the flags.
- All courses should be measured fairly and reasonably on the 'riding line.'
- CDs should never try to 'catch horses out,' surprise horses, or use unfair distances, but rather always give horses two or three strides to understand the question and offer a positive experience.
- All courses should be preparing horses and riders for the next level of competition, therefore need to be at the appropriate level of difficulty.
- CDs should be looking to show horses what they can do, not what they can't, at every level.
- All courses should 'flow' and allow riders to maintain a good rhythm. CDs should not attempt to slow horses down at the expense of flow.
- Wherever possible have turns before a fence to help the horse's balance rather than after fences.
- CDs must encourage the average rider on an average horse to produce a good 'picture.'

ANCHORING FENCES

Just because a fence is heavy it can never be assumed that it won't move when hit by a horse. If a fence moves it significantly increases the chance of a rotational fall. All fences must be anchored into the ground and rendered immobile to keep the fence from flipping or sliding.

FRANGIBLE DEVICES

Please refer to the *USEF Rules For Eventing* and inside.fei.org/fei/disc/eventing/risk-management/devices

The use of a frangible device cannot justify the use of the wrong fence in the wrong place.

HORSE VISION

Horses are dichromatic and therefore see in contrast, believed to be in shades of yellow and blue as opposed to humans who are trichromatic and see in color. Therefore, the contrast between the top of the fence and the background are of paramount importance.

It is believed that horses take up to seven times longer than humans to adjust from light to dark and vice versa. CDs should therefore be very aware of shadow and light into dark. Horses should have at least two strides to adjust in the 'dark' before a fence.

Horses are prey animals that can see through 340 degrees but cannot see 10 degrees in front or 10 degrees behind. This means that in the last 5m/16.4' the horse gains more and more information from the sides and less and less from directly in front.

Decoration on the top corners of spread fences help the horses to read the front and back of spreads. A pair of flags set in the middle of a spread fences with no other decoration is not advised as the flags take away from the horses ability to read the leading edge.

Any decoration in front of the leading edge (trees, shrubs) helps the horse to read the leading edge and therefore helps to keep the horse away from the leading edge.

GROUND LINES

All fences have an anticipated speed depending on terrain, direction of approach, profile of jump, etc. The average take off point is directly related to the anticipated speed and height of the leading edge of the jump.

The ground line is to help the average horse take off at a safe distance from the jump. The closer to the fence the ground line, the taller it should be.

Examples:

- Obstacles at 1.20m/47" high with the anticipated speed of horse at 300mpm; the average horse should not get closer than .90m/35".
- Obstacles at 1.20m/47" high with the anticipated speed of horse at 450mpm; the average horse should not get closer than 1.35m/53".
- Obstacles at 1.20m/47" high with the anticipated speed of horse at 600mpm; the average horse should not get closer than 1.80m/71".

Ground lines can be rails, mulch, flowers, pine straw, etc.

The ground line is part of the overall base spread dimension and should not exceed the max base spread according to *USEF Rules For Eventing Appendix 2*.

There should be no grass/dirt between the ground line and front of fence, where the horse might put a leg down in front of fence.

False ground lines should never be used.

LEADING EDGES

From the *FEI Eventing Cross-Country Guide for Officials*

Leading Edges (art. 547.2.6)

It is essential that every effort is made to avoid unforgiving leading edges on any fence. Research has shown that the more a Horse's mass can be deflected and the less it is stopped at impact the more forgiving the fence and the less the chance of a rotation. In the same vein a smooth surface is more forgiving than rough bark.

Any front leading edge must not be in front of the base of a fence. Where an angled

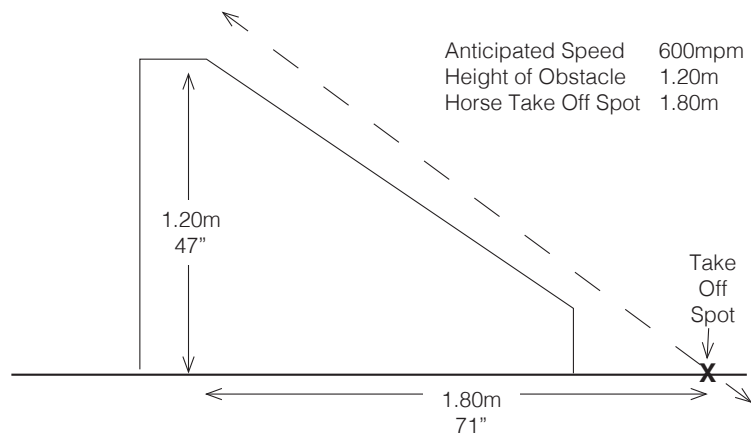
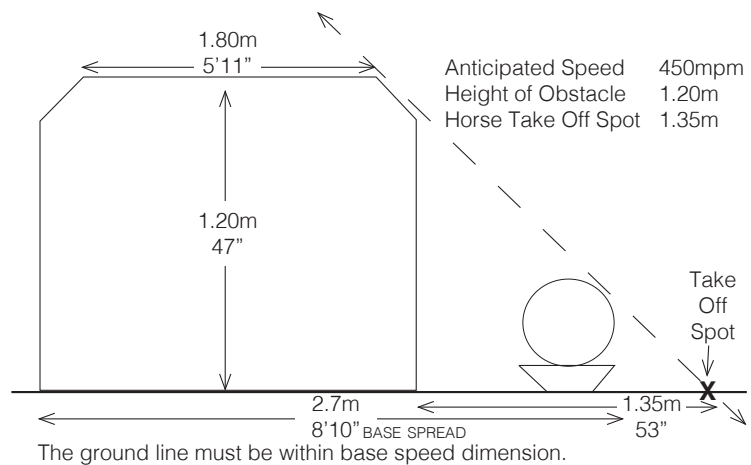
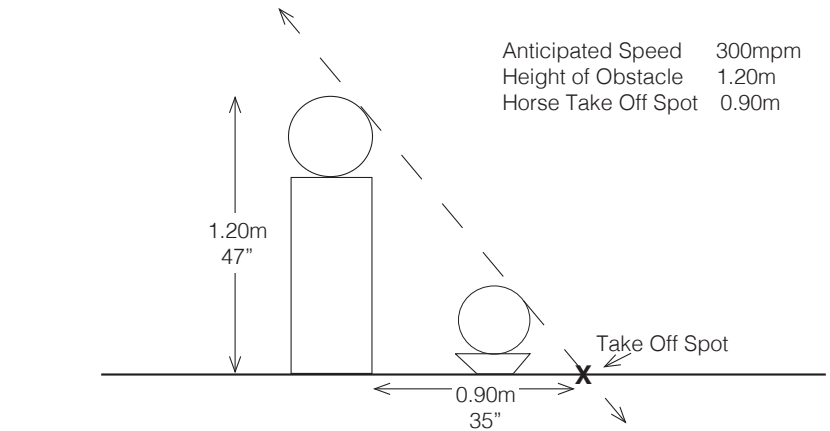

section has been added to the front of an existing fence use the ground line and any necessary filling/dressing to prevent a horse hitting the front of the angled part from underneath.

As a recommendation, front leading edge of spread fences, corners, etc. should be sloped at 45° (with a margin of +/- 5°) to a point 20cm below the highest point of the leading edge.

Solid top spread fences—there should be nothing protruding from the front of a fence such as a half round which a horse may catch a leg on as it comes upwards in its jumping trajectory.

Ascending fences - the front of any spread fence, such as a house or flower box, must be no less than 25cms from the height of the fence unless it is rounded.

COMBINATIONS AND RELATED DISTANCES

Combinations of four strides or less should be on a true distance. A true distance relates to the average strides a horse would take between elements.

At Modified and above all four stride combinations are jumped at approximately 400-450mpm. As the distance controls the length of the stride and speed. CDs should understand that at 300mpm the horse will take a shorter stride and at 500mpm a longer stride. Therefore the anticipated speed of approach is critical at every related distance.

BENDING LINE COMBINATIONS

The diagram to the right is a guide to the recommended number of strides between elements with top spread at different angles between fences. This is intended to help with the flow of bending lines so that horses are not pulled about between fences.

It is accepted that horses take a slightly shorter stride on a bending line than when they are on the straight away.

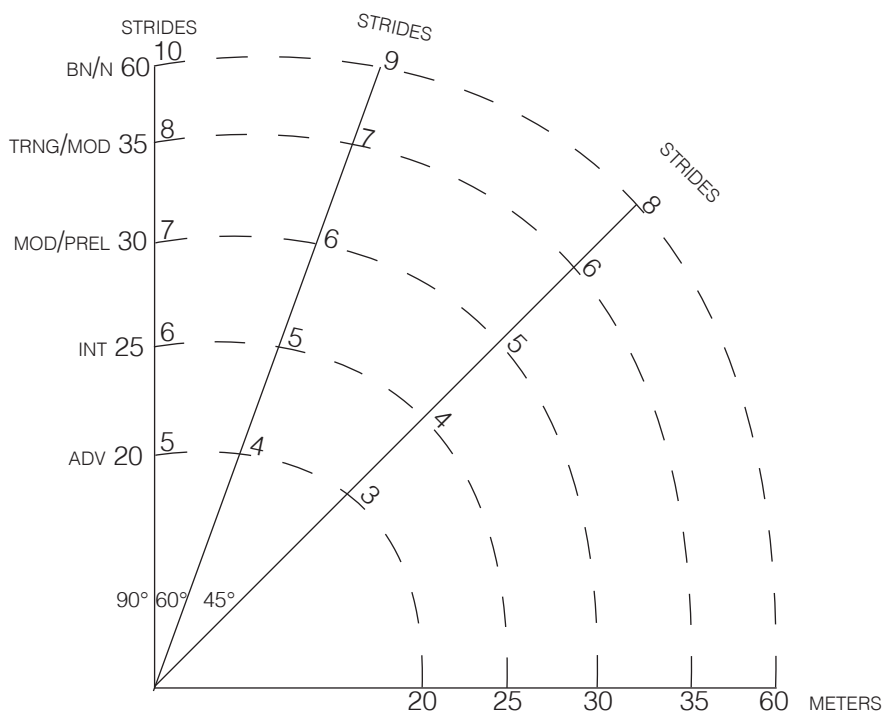

APPROACH

- Upslope – easier for a horse to jump.
- Downslope – more difficult for a horse to jump so the height of a fence on a downslope should normally be 2” below maximum.
- Straight – more difficult for the rider to balance the horse.
- Off a turn – easier for the rider to balance the horse.

The length of a horse’s stride will tend to lengthen on a gentle downslope, so those fences will need a bigger ground line.

Similarly the length of stride on a gentle upslope will tend to shorten the horse’s stride, therefore, less ground line required.

The faster the anticipated approach the longer the horse’s stride. *See Ground Lines.*

With a steep slope up or down the horse’s stride will shorten. The switchover must be a discussion between the CD, TD, and Ground Jury when looking at related distances and the size of ground lines.

FENCES

UPRIGHT/VERTICAL

A vertical fence without a ground line should not be used at any level other than Advanced and then only off a bend or on an upslope.

Upright fences should normally have two rails and a ground line or three rails to create a convex profile.

Verticals are inappropriate for Beginner Novice, Novice, and Training. All uprights Training and above should be frangible when possible.

OXERS

The front profile of an oxer should be the same as an upright.

For Beginner Novice, Novice, and Training the back rail should be 2" higher than the front rail.

For Modified and above the back rail should be 1" higher than the front rail.

For Training and above it is recommended to use the MIM Clip on the front rail and the Reverse Pin on the back rail.

BANKS (STEP UP/STEP DOWN)

Appropriate for all levels.

At all levels the height of the step up onto a bank should be at least 4" below maximum.

Beginner Novice and Novice should have a minimum of 43'6" (three strides) across the top.

Training and Modified should have a minimum of 18' or 30' (one or two strides) across the top.

Preliminary and above should have a minimum of 12' across the top.

BANKS (CORNISH, IRISH, AND NORMANDY)

Not appropriate for Beginner Novice, Novice, and Training.

If a Cornish Bank can be jumped in one effort, the rails need to be within maximum dimensions.

An Irish Bank must have a retaining wall (wood or stone) on both sides. This should be approximately 2' – 2'6" as the exercise is to jump up on to the face of the bank, take a stride(s) over the top, and jump off.

A Normandy Bank has a step (see steps) and then a bounce (12' – 13'6") for Advanced only or a one stride (18') for Modified, Preliminary, and Intermediate.

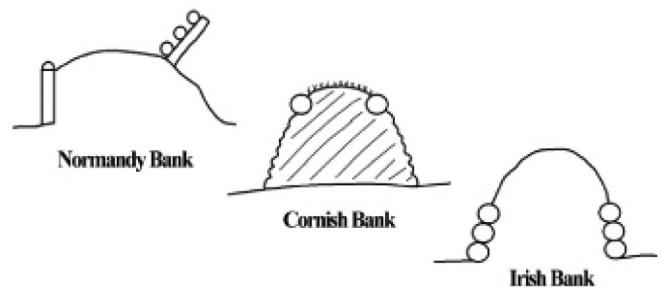

BENCH/SEAT

Appropriate for all levels.

A sloping back to the seat is preferable.

The seat should be no more than 1/3 the height of the fence and the depth of the seat, from the front of the seat to the front of the top, should not exceed 2/3 the height.

BRUSH BOX/FRAME

Appropriate for all levels.

The height of the brush box should be 4" below maximum at the front and 6" at the back.

At all levels 12" of brush is recommended above the height of the box/frame.

Brush Frame is always safer, as the back of the frame is lower than the front, not allowing a horse to slide a leg into frame.

BULLFINCH

Not appropriate for Beginner Novice, Novice, and Training.

The height of the box (frame) is the same as for a normal brush fence.

The see through brush should be approximately 2'-3' higher than the brush and must be of only token thickness for Modified and Preliminary.

CABIN/FEEDER/ROOF SHAPE

Appropriate for all levels.

The slope on the roof should be approximately 45 degrees.

A roof shape with a question beyond (water, ditch, step, drop, etc) should have a 'short back' i.e. 50% of the depth, compared to the front.

COFFIN

Not appropriate for Beginner Novice.

Novice can have a half coffin with a fence before or after the ditch.

The height of the element before the ditch should be 2" below maximum for all levels.

The height of the element after the ditch should be maximum for all levels.

Distances on flat ground:

LEVEL	DISTANCE BEFORE DITCH	DISTANCE AFTER DITCH	DITCH WIDTH (outside to outside measurement)
Novice	43' 6"	45'	2'6"
Training	30'	33'	3'6"
Modified	18'	21'	4'
Preliminary	18'	21'	4'
Intermediate	15-18'	10'6" or 18'	4'6"
Advanced	10'6" or 15'	10'6" or 18'	5'

Ditch should be approximately 2' deep.

Distances will vary with slope, downslope – longer, upslope – shorter.

CORNERS

Appropriate for all levels.

All levels should have a tear drop ground line.

All Beginner Novice and Novice corners should be boarded in.

For Beginner Novice, Novice, and Training, the back should be 2" higher than the front.

The top spread of a corner at Beginner Novice, Novice, and Training should measure within 150cm/60" from the apex of the corner.

At Beginner Novice, Novice, and Training levels, the top spread of a corner should be measured at 90 degrees to the bisecting angle.

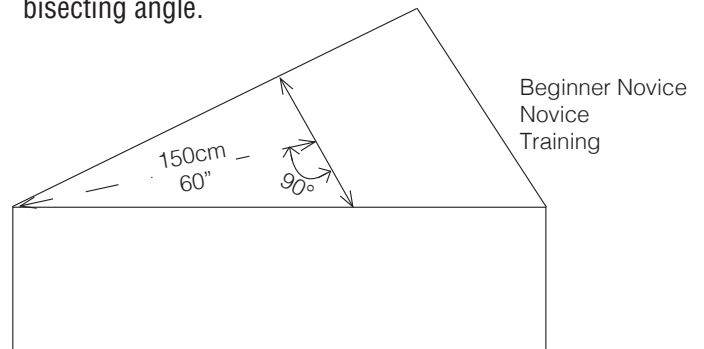

For Modified upwards, the back should be 1" higher than the front.

The top spread of corners at Modified, Preliminary, Intermediate, and Advanced should measure within 85cm/34" from apex of the corner when jumping the bisecting line at 90 degrees.

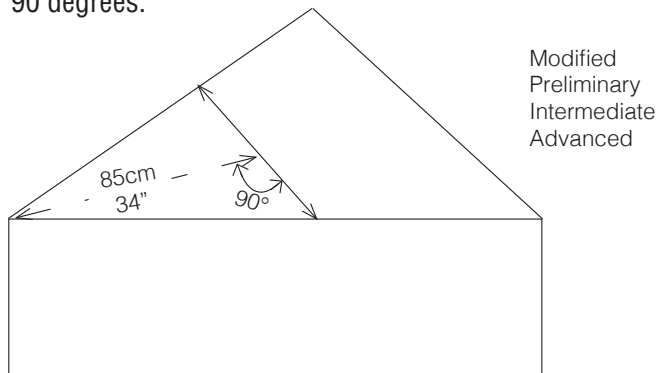

LEVEL	DEGREE OF ANGLE	TOP SPREAD
Beginner Novice	15-20 degrees	150cm/60"
Novice	20-25 degrees	150cm/60"
Training	30-35 degrees	150cm/60"
Modified	40-45 degrees	85cm/34"
Preliminary	45-55 degrees	85cm/34"
Intermediate	55-65 degrees	85cm/34"
Advanced	70-80 degrees	85cm/34"

CROSS QUESTION

Only appropriate for Intermediate and Advanced.

Should have 16' total width

DITCH BRUSH

Appropriate for all levels.

The height of the brush box should be 4" below maximum at the front and 6" at the back.

At all levels 12" of brush is recommended above the box/frame. It is recognized that there is less risk to the horse with brush in a frame as opposed to brush in a box if the horse ends up in the ditch.

Beginner Novice and Novice can have a scoop to create an insignificant (12" – 18") ditch behind a take off rail.

For Training upwards the ditch should be 2' deep and 14' – 16' long.

If the ground is slightly rising in the last stride, this greatly helps the horse.

A base spread 1' below maximum is recommended.

For a Weldon's Wall the base spread should never be more than two-thirds maximum.

DOUBLE BRUSH

Appropriate for all levels.

The height of the brush box should be 4" below maximum at the front and 6" at the back.

The height of the brush at the front should be 2" lower than the back.

All boxes should be decked in with a 2" lip on the back to stop the horse from slipping into the second brush.

ELEPHANT TRAP

Appropriate for all levels.

The highest point of the rail must not be further back than $\frac{3}{4}$ of the way across the base spread.

HELSINKI

Not appropriate for Beginner Novice and Novice.

The height in the middle of each section should be 2" below maximum.

LEVEL	JUMPABLE WIDTH
Training	Not less than 10'
Modified	Not less than 8'
Preliminary	Not less than 7'
Intermediate	Not less than 6'
Advanced	Not less than 5'

KEY HOLE

Not appropriate for Beginner Novice, Novice, and Training.

Solid box – see Brush Boxes

Top spread is not recommended, but should never be more than 50% of maximum.

LEVEL	SIZE OF HOLE DIAMETER
Modified	8'
Preliminary	7'
Intermediate	6' 6"
Advanced	6'

There should be 2' of brush between the top of the aperture and the solid part of the frame.

LOG PILE

Appropriate for all levels.

NARROWS

Appropriate for all levels.

LEVEL	MINIMUM JUMPABLE WIDTH
Beginner Novice	12'
Novice	10'
Training	8'
Modified	6'3"-6'7" (1.90m-2.00m)
Preliminary	5'5"-5'11" (1.65m-1.80m)
Intermediate	4'11"-5'5" (1.50m-1.65m)
Advanced	4'7"-4'11" (1.40m-1.5m)

Narrows jumped on a bending line or at an angle should be 6" wider than the minimum above. When a narrow is jumped from a straight approach or with a brush shoulder the jump can be at its narrowest.

OPEN DITCH

Appropriate for all levels.

LEVEL	INSIDE WIDTH
Beginner Novice	2' (scoop)
Novice	2' 6"
Training	3' 6"
Modified	4'
Preliminary	4' 6"
Intermediate	6'
Advanced	8'

All ditches other than Beginner Novice should be approximately 2' deep.

PALISADE/RAMP

Appropriate for all levels.

The slope of all palisades/ramps should be not less than 45 degrees or more than 60 degrees.

PICTURE FRAME

Not appropriate for Beginner Novice and Novice.

Height of the solid part should be 1" below maximum.

LEVEL	MINIMUM APERTURE
Training	8' x 8'
Modified	7'6" x 7'6"
Preliminary	7' x 7'
Intermediate	6'6" x 6'6"
Advanced	6' x 6'

ROOFS

Not appropriate for Beginner Novice, Novice, and Training.

A fence under a roof should be no less than 1" under maximum and if a table the front should be 2" lower again.

A fence under a roof should not have more than 50% maximum top spread.

The 'eve' of the roof should be a minimum of 11' from the ground.

Never use in association with water.

Use pale colors if fence is shaded.

ROUND TOP

Appropriate for all levels.

SHARKS TEETH

Appropriate for all levels.

STEPS

Appropriate for all levels.

At all levels the height of a step up should be 4" below maximum.

At Beginner Novice a maximum of two steps with a minimum of three strides (45') between.

At Novice a maximum of two steps with a minimum of two strides (33') between.

Training can have one stride (21') or more between a maximum of two steps.

Modified should have one stride (21') between steps.

Preliminary and above can introduce a bounce (10'6" to 12') between steps.

Three steps up with a bounce are not recommended at any level.

At any step combination, if the ground rises slightly between the steps it helps the horse read the question.

SUNKEN ROAD

Not appropriate for Beginner Novice and Novice.

Training and Modified could have half a sunken road, that is step in or out, with a ramp in or out. In both cases a fence should be not less than 30' before the step or ramp and not less than 30' after the step or ramp, and not less than 30' between the step and ramp, and should always be on flat terrain.

Preliminary can have step in and out with 21' between steps and a fence 18' before and after the second step.

Intermediate can have step in and out with 20'-21' between steps with a fence 16'-18' before step and 9'-12' or 18' after the second step.

Advanced can have steps in and out with 19'-21' between steps, with a fence 10'6" before step and 9'-12' or 18' after the second step.

At all levels, rails or logs are best so that the horse can 'see through' them and understand the question better. All distances are 'inside distances.'

The height of first element should be 2" below maximum.

The height of the last element should be maximum.

Height of steps – see steps.

At all levels distances should be adjusted for up slope (shorter), downslope (longer) and longer where the step up is smaller.

TABLE

Appropriate for all levels.

All levels must have either a sloped or rounded leading edge of approximately 45 degrees to a point 8" below the top of the table at the front.

Where the leading edge is less than 8" below the height of the obstacle, that too should have a sloped or rounded edge.

For Beginner Novice, Novice, and Training the back of the table must be 2" higher than the front and 1' higher for Modified and above.

TRAKEHNER

Appropriate for all levels with a large (not less than 18") log.

Beginner Novice and Novice should have a shallow scoop ditch under. Training and above can have a reveted ditch that must be not more than 2' deep.

Maximum base spread is not recommended at any level. Base spread should be proportional to the size of the log (bigger log = more base spread, small log = less base spread).

At all levels the take off should be defined by a prominent ground line.

TRIPLE BRUSH

Appropriate for all levels.

Beginner Novice and Novice are normally two brushes not three.

Minimum dimensions:

LEVEL	WIDTH		HEIGHT		BASE SPREAD
	FRONT	BACK	FRONT	BACK	
Beginner Novice	8'	12'	1'	2'	2'6"
Novice	6'	10'	1'	2'7"	3'
Training	3'6"	8'	1'6"	2'11"	3'6"
Modified	2'6"	7'	1'6"	3'1"	4'
Preliminary	2'6"	6'	1'6"	3'3"	4'6"
Intermediate	2'	5'6"	1'6"	3'5"	5'6"
Advanced	1'6"-2'	4'6"	1'6"	3'7"	6'

All brushes should be cut to produce a straight or concave(easier) shape.

WATER

Appropriate for all levels.

Beginner Novice and Novice – see *USEF Rules For Eventing*.

Depth of water 6"-10".

Height of fence into water should never be more than 2" below maximum height.

LEVEL	MAXIMUM DROP INTO WATER
Training	2'8"
Modified	3'10"
Preliminary	4'7"
Intermediate and Advanced	Maximum can be used if used with brush.

Water crossings should be a minimum of 30' across.

Any fence in water is appropriate for Training and above and should have a minimum of 19'6" of water before and should be 2" below maximum height. A round shape is preferable but never more than 50% maximum top spread.

Where there is a jump into water and a revetted step out, the step must be not less than 45' after the fence in.

All steps out of water should have a ground line.

Fences after a step out of water:

LEVEL	MINIMUM OF FEET
Training	30'
Modified	18'
Preliminary	18'
Intermediate and Advanced	9'-12'

All distances need to be proportional to the height of the step, smaller step = more distance, larger step = smaller distance.

ZIG ZAG WITH OR WITHOUT DITCH

Not appropriate for Beginner Novice, Novice, Training, or Modified.

Total width should be not less than 16'.

The angle of the rails should be shallow for Preliminary.

If with ditch, the base spread should be at least 1' below maximum.